



# MDPM07

4Q PWM Open Chassis Microprocessor-based  
Adjustable Speed Drive with Isolation  
& Torque Mode for PMDC Brushed Motors

An American Control Electronics Brand

## Specifications

| Model              | Line Voltage (VAC) | Armature Voltage Range (VDC) | Continuous Armature Current (Amps) | Motor Horsepower Range                 |
|--------------------|--------------------|------------------------------|------------------------------------|--|
| MDPM07-D230-4Q-PCM | 115 or 230         | 0 - 90 or 0 - 130 or 0 - 180 | 7.0*                               | 1/20 - 2/3 or 1/20 - 1 or 1/10 - 1 1/3 |

\* When mounted to allow upwards airflow through the heat sink fins. De-rate to 5.5 amps when mounted in any other configuration.

|   |  |
|---|--|
| AC Line Voltage   | 115/230 VAC ± 10%, 50/60 Hz, single phase  |
| Acceleration Time Range for 90 / 130 VDC armature voltage | 0.5 - 11 seconds                           |
| for 180 VDC armature voltage                              | 0.5 - 20 seconds                           |
| Deceleration Time Range for 90 / 130 VDC armature voltage | 0.5 - 11 seconds                           |
| for 180 VDC armature voltage                              | 0.5 - 20 seconds                           |
| Analog Input Signal Range                                 | 0 ± 5 VDC, 0 ± 10 VDC, 4 - 20 mA           |
| Input Impedance (S1 to S2)                                | >50K ohms                                  |
| Form Factor   | 1.05                                       |
| Load Regulation   | 1% base speed or better                    |
| Speed Range   | 100:1                                      |
| Maximum Vibration (0 - 50 Hz, >50 Hz)                     | 0.5G, 0.1G maximum                         |
| Surrounding Air Temperature Range                         | 32°F - 104°F (0°C - 40°C)                  |
| Weight  | 2.42 lbs (1.10 kilograms)                  |
| Safety Certifications                                     | cULus Listed, UL 61800-5-1, File # E132235 |

## Safety Warnings

### READ ALL SAFETY WARNINGS BEFORE INSTALLING THIS EQUIPMENT

- DO NOT INSTALL, REMOVE, OR REWIRE THIS EQUIPMENT WITH POWER APPLIED. Have a qualified electrical technician install, adjust, and service this equipment. Follow the National Electrical Code and all other applicable electrical and safety codes, including the provisions of the Occupational Safety and Health Act (OSHA), when installing equipment.
- Circuit potentials are at 115 or 230 VAC above earth ground. Avoid direct contact with the printed circuit board or with circuit elements to prevent the risk of serious injury or fatality. Use a non-metallic screwdriver for adjusting the calibration trim pots. Use approved personal protection equipment and insulated tools if working on this drive with power applied.
- Reduce the chance of an electrical fire, shock, or explosion by using proper grounding techniques, over-current protection, thermal protection, and enclosure. Follow sound maintenance procedures.
- Minarik Drives strongly recommends the installation of a master power switch in the line voltage input. The switch contacts should be rated for 250 VAC and 200% of motor nameplate current.
- Removing AC line power is the only acceptable method for emergency stopping. Do not use regenerative braking, decelerating to minimum speed, or coasting to a stop for emergency stopping. They may not stop a drive that is malfunctioning.
- Line starting and stopping (applying and removing AC line voltage) is recommended for infrequent starting and stopping of a drive only. Regenerative braking, decelerating to minimum speed, or coasting to a stop is recommended for frequent starts and stops. Frequent starting and stopping can produce high torque. This may cause damage to motors.
- Do not disconnect any of the motor leads from the drive unless power is removed or the drive is disabled. Opening any one lead while the drive is running may damage the drive.
- Under no circumstances should power and logic level wires be bundled together.
- Be sure potentiometer tabs do not make contact with the potentiometer's body. Grounding the input will cause damage to the drive.
- Only connect to terminal L2-DBL if using a 115 VAC line with a motor rated higher than 130 VDC.
- This product does not have internal solid state motor overload protection. It does not contain speed-sensitive overload protection, thermal memory retention, or provisions to receive and act upon signals from remote devices for over temperature protection. If motor protection is needed in the end-use product, it needs to be provided by additional equipment in accordance with NEC standards.

## Dimensions

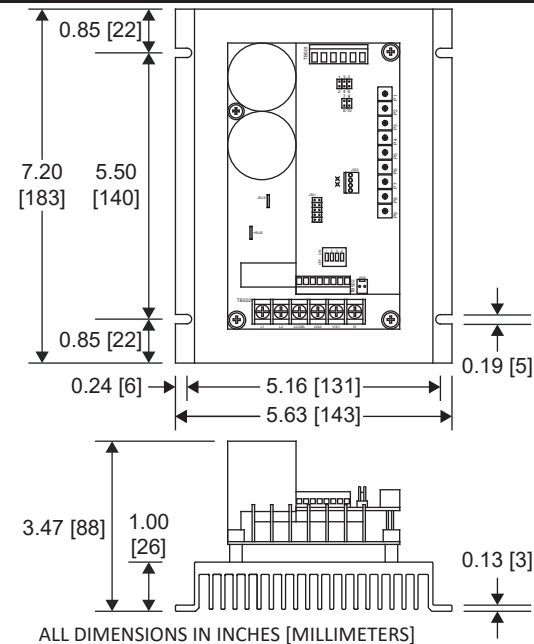

## Installation

### Mounting

- Drive components are sensitive to electrostatic discharge. Avoid direct contact with the circuit board. Hold the drive by the heat sink only.
- Protect the drive from dirt, moisture, and accidental contact.
- Provide sufficient room for access to the terminals and calibration trim pots.
- Mount the drive away from heat sources. Operate the drive within the specified surrounding air operating temperature range.
- Prevent loose connections by avoiding excessive vibration of the drive.
- Mount the drive with its board in either a horizontal or vertical plane. Four 0.19" (5 mm) wide slots in the heat sink accept #8 pan head screws. If mounted horizontally, the drive must be de-rated to 5.5 amps.
- The heat sink should be earth grounded.

**Wiring:** Use 16 - 18 AWG 75°C wire for AC line (L1, L2, L2-DBL) and motor (U/A2, V/A1) wiring. Use 18 - 24 AWG wire for logic wiring (COM, DIR, EN, S1, S2, S3). Follow NEC standards for wiring. Tightening torque for power terminal TB502 on the bottom board is 9 lb-in (1.0 N-m). Tightening torque for logic terminals TB501 and TB502 on the top board is 1.77 lb-in (0.2 N-m).

**Shielding Guidelines:** As a general rule, it is recommended to shield all conductors. If it is not practical to shield power conductors, it is recommended to shield all logic-level leads. If shielding of logic-level leads is not practical, the user should twist all logic leads with themselves to minimize induced noise. It may be necessary to earth ground the shielded cable. If noise is produced by devices other than the drive, ground the shield at the drive end. If noise is generated by the drive, ground the shield at the end away from the drive. Do not ground both ends of the shield.

**Short Circuit Current Rating (SCCR):** This drive is suitable for use on a circuit capable of delivering not more than 5,000 rms Symmetrical Amperes, 115/230 volts maximum.

**Branch Circuit Protection:** This product has integral solid state circuit protection, which does not provide branch circuit protection. Branch circuit protection must be provided in accordance with the National Electrical Code and any additional local codes. The UL Listing requires the use of Class J, Class CC, or Class T fuses rated at a minimum of 230 VAC. It is recommended to use fuses rated for 200% of the maximum motor current, unless using the drive in doubler operation, in which case the fuses should be rated for 400% of maximum motor current. Fuse the HOT leg of the AC line when using 115 VAC and both lines when using 230 VAC.

### POWER (BOTTOM BOARD)

#### AC Line Input

Connect the AC line voltage to terminals L1 and L2. If doubler mode is to be used (180 VDC output with 115 VAC input), connect the AC line voltage to terminals L1 and L2-DBL. Do not make any connections to L2-DBL if using a 230 VAC line source.

#### Motor

Connect the DC armature leads to terminals U/A2 and V/A1. If the motor does not spin in the desired direction, power down the drive and reverse these connections.

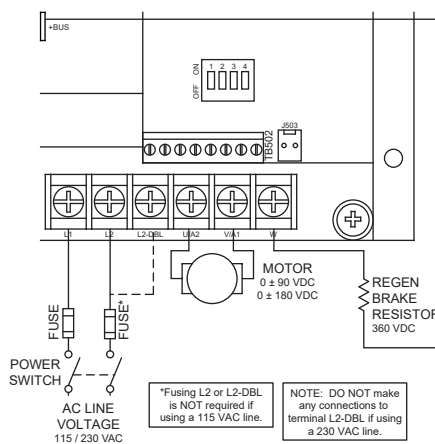

## Connections

### LOGIC (TOP BOARD)

#### Speed Potentiometer

Use a 10K ohm, 1/4 W potentiometer for speed control. Connect the counter-clockwise end of the potentiometer to S1, wiper to S2, and the clockwise end to S3. If the potentiometer works inversely of desired functionality, (i.e. to increase motor speed, you must turn the potentiometer counterclockwise), power off the drive and swap the S1 and S3 connections.

#### Analog Input Signal Range

Instead of using a potentiometer, the drive may be wired to follow an analog input signal. This input signal can be in the form of voltage (0 ± 5, 0 ± 10 VDC) or current (4-20 mA). The built in isolation allows the the input signal to be grounded or ungrounded (floating). Connect the signal common / negative (-) to S1 and the signal reference /positive (+) to S2. Refer to the Startup section for related jumper settings.

#### Enable

Short terminals EN and COM to accelerate the motor to set speed. Open the ENABLE terminals to coast or brake the motor to zero speed. Refer to DIP Switch 3 in the Startup section for jumper settings. If no ENABLE switch is desired, wire a jumper between terminals COM and EN.

**Do not use the enable for emergency stopping.**

#### Direction

Short terminals DIR and COM to change the direction of the motor. If no direction switch is desired, leave this connection open.

#### Brake Resistor

PWM drives are limited in their regenerative capability. The regenerative energy is returned into the drive's bus capacitor. When this capacitor is full, the drive can no longer regen until the capacitor begins to empty. During these periods, the motor actually coasts. While the regen/coast periods are frequent enough that the user may not see the transitions, it does result in a longer deceleration time. The solution is a brake resistor. When the capacitor is full, the drive will divert the regen energy through the resistor. If using a regenerative brake resistor, connect the resistor across terminals W and +BUS. Refer to the Operation section for resistor sizing.

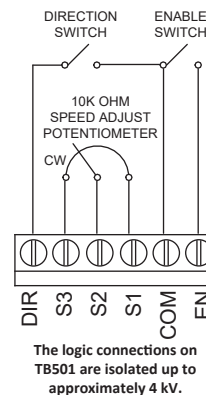

# Startup

## SELECT SWITCHES

### Select Switch (SW501)

Dip Switch 1: ON - Torque Mode - The drive will control the torque (current) of the motor. This is used in tensioning applications.

OFF - Speed Mode - The drive will control the speed (voltage) of the motor. This is used in variable speed applications.

Dip Switch 2: ON - WigWag Mode - The potentiometer or analog signal determines both motor speed and direction. The direction switch will still come into effect.

|               | Full Speed Reverse | Zero Speed | Full Speed Forward |
|---------------|--------------------|------------|--------------------|
| Potentiometer | Full CCW           | 12 o'clock | Full CW            |
| 0 - 5 VDC     | 0 VDC              | 2.5 VDC    | 5 VDC              |
| 0 - 10 VDC    | 0 VDC              | 5 VDC      | 10 VDC             |
| 4 - 20 mA     | 4 mA               | 12 mA      | 20 mA              |

OFF - Pot/Switch Mode - The potentiometer or analog signal (0 - 5 VDC, 0 - 10 VDC, 4-20 mA) determines the motor speed while the direction switch determines the direction. If using a bidirectional analog signal (0 ± 10 VDC), the polarity of the signal determines the direction (ie -10 VDC is full speed reverse, 0 VDC is zero speed, 10 VDC is full speed forward). The direction switch will still come into effect even with a bidirectional signal.

Dip Switch 3: ON - Brake Mode - Opening the ENABLE switch will regeneratively brake the motor to zero speed without applying the decel ramp. At zero speed, the drive will apply holding torque.

OFF - Enable Mode - Opening the ENABLE switch will coast the motor to a stop. The drive cannot provide holding torque at zero speed because it's disabled.

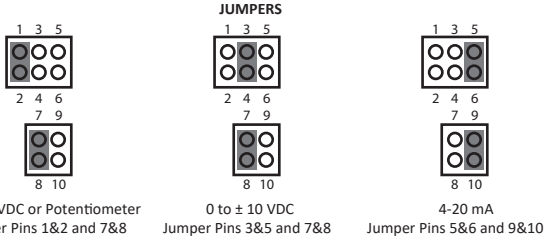

## LEDs

**Power (IL1):** Green LED is solid when AC line voltage is applied to the drive, but the drive is disabled. It flashes whenever AC line voltage is applied to the drive and the drive is enabled.

**Status (IL2):** Red LED is solid when in current limit or flashes following fault code:

2 Flashes: Undervoltage - Internal DC BUS voltage dropped too low.

3 Flashes: Overvoltage - Internal DC BUS voltage rose too high.

4 Flashes: Current Limit or Short Circuit - The drive is in current limit or has detected a short across the motor.

5 Flashes: Overtemperature Shut Down - Drive's temperature has reached critical temperature.

6 Flashes: Overtemperature Warning - Drive's temperature is approaching critical temperature.

Maximum motor current is being reduced gradually as the drive's temperature rises.

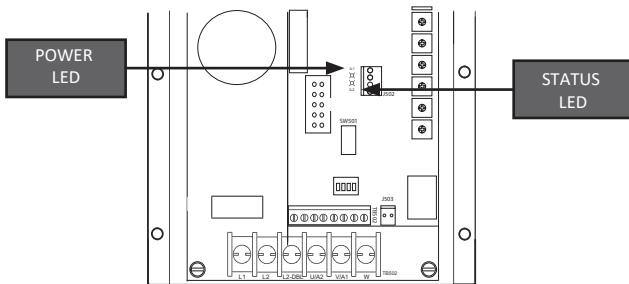

Copyright 2018 by American Control Electronics® - All rights reserved. No part of this document may be reproduced or retransmitted in any form without written permission from American Control Electronics®. The information and technical data in this document are subject to change without notice. American Control Electronics® makes no warranty of any kind with respect to this material, including, but not limited to, the implied warranties of its merchantability and fitness for a given purpose. American Control Electronics® assumes no responsibility for any errors that may appear in this document and makes no commitment to update or to keep current the information in this document.

## STARTUP

- Verify that no foreign conductive material is present on the printed circuit board.

- Ensure that all switches and jumpers are properly set.

1. Turn the speed adjust potentiometer full counterclockwise (CCW) or set the analog input signal to minimum.
2. Apply AC line voltage.
3. Close the enable switch and verify that the green Power LED (IL1) if flashing.
4. Slowly advance the speed adjust potentiometer clockwise (CW) or increase the analog input signal. The motor should accelerate as the potentiometer is turned CW or as the analog signal is increased. Continue until the desired speed is reached.
5. Remove AC line voltage from the drive to coast the motor to a stop.

# Operation

## DECELERATING & STOPPING

### Decelerate to Minimum or Zero Speed

The switch shown below may be used to decelerate a motor to a minimum speed. Opening the switch between S3 and the potentiometer decelerates the motor from set speed to a minimum speed determined by the MIN SPEED trim pot setting. If the MIN SPEED trim pot is set full CCW, the motor decelerates to zero speed when the switch is opened. The DECEL TIME trim pot setting determines the rate at which the drive decelerates. By closing the switch, the motor accelerates to set speed at a rate determined by the ACCEL TIME trim pot setting.

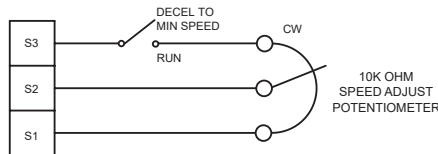

## REGENERATIVE BRAKE RESISTOR RESISTANCE SIZING

| Braking Torque / Current* Needs (Amps) | Longest Brake ON Time (Secs) | Braking Duty Cycle - Brake ON vs OFF (%) | Minimum Brake Resistor Resistance (Ω) | Maximum Brake Resistor Resistance (Ω) |
|--|------------------------------|--|---------------------------------------|---------------------------------------|
| 1                                      | 40                           | 50                                       | 40                                    | 400                                   |
| 1.5                                    | 30                           | 40                                       | 40                                    | 250                                   |
| 2                                      | 25                           | 30                                       | 40                                    | 200                                   |
| 3                                      | 20                           | 20                                       | 40                                    | 125                                   |
| 5**                                    | 15                           | 10                                       | 40                                    | 80                                    |
| 7                                      | 12                           | 5  | 40                                    | 60                                    |
| 10                                     | 10                           | 2  | 40                                    | 40                                    |

\* "Braking current needs" can either be measured in the actual application, or they can be calculated based on motor characteristics, load characteristics and desired deceleration rates/times.

## REGENERATIVE BRAKE RESISTOR WATTAGE SIZING

Brake resistor power rating requirements:

### 1. Instantaneous power rating requirement (resistor's ability to survive power pulse)

$$\text{Maximum Instantaneous Power} = \text{Braking Current} * \text{Initial Braking Voltage}$$

"Initial braking voltage" can be approximated with voltage needed for the motor to be running at the RPM at start of braking. If motor is running at rated RPM before braking then "Initial braking voltage" would be rated voltage. If running at reduced RPM then "Initial braking voltage" can be reduced proportionally.

### 2. Short term power rating requirement (resistor's ability to survive one braking cycle)

- a. If motor is being decelerated to a stop  
Maximum Short Term Power =  $\frac{1}{2} * \text{Braking Current} * \text{Initial Braking Voltage}$
- b. If braking action is opposing an overhauling load so the motor does not slow down  
Maximum Short Term Power =  $\text{Braking Current} * \text{Braking Voltage}$

"Braking voltage" can be approximated with proportion of rated voltage that correlates to RPM during braking.

### 3. Long term (continuous) power rating requirement (resistor's ability to absorb/dissipate power over time without overheating/failing)

- a. If motor is being decelerated to a stop  
Maximum Continuous Power =  $\frac{1}{2} * \text{Braking Current} * \text{Braking Voltage} * \text{Braking Duty Cycle}$
- b. If braking action is opposing an overhauling load so the motor does not slow down  
Maximum Continuous Power =  $\text{Braking Current} * \text{Braking Voltage} * \text{Braking Duty Cycle}$

# Calibration

**Zero Adjust (P1):** The ZERO ADJ setting adjusts out any non-linearities in the logic circuit that might arise from component tolerances. This factory calibrated and should not need any adjustment.

**Minimum Speed (P2):** The MIN SPEED setting determines the minimum motor speed when the speed adjust potentiometer or analog signal is set for minimum speed (full CCW). It is factory set for zero speed. To calibrate the MIN SPEED:

1. Set the MIN SPEED trim pot full CCW.
2. Set the speed adjust potentiometer or analog signal for minimum speed.
3. Adjust the MIN SPEED trim pot until the desired minimum speed is reached or is just at the threshold of rotation.

**Maximum Forward Speed (P3):** The MAX FWD SPEED setting determines the maximum motor speed in the forward direction when the speed adjust potentiometer or analog signal is set for maximum speed. It is factory set for maximum motor rated speed. To calibrate the MAX FWD SPEED:

1. Set the MAX FWD SPEED trim pot full CCW.
2. Set the speed adjust potentiometer or analog signal for maximum forward speed.
3. Adjust the MAX FWD SPEED trim pot until the desired maximum forward speed is reached.

**Maximum Reverse Speed (P4):** The MAX REV SPEED setting determines the maximum motor speed in the reverse direction when the speed adjust potentiometer or analog signal is set for maximum speed. It is factory set for maximum motor rated speed. To calibrate the MAX REV SPEED:

1. Set the MAX REV SPEED trim pot full CCW.
2. Set the speed adjust potentiometer or analog signal for maximum reverse speed.
3. Adjust the MAX REV SPEED trim pot until the desired maximum reverse speed is reached.

Check the MINIMUM SPEED, MAX FWD SPEED, and MAX REV SPEED adjustments after recalibrating to verify that the motor runs at the desired minimum and maximum speeds.

**Acceleration (P5):** The ACCEL TIME setting determines the time the motor takes to ramp to a higher speed regardless of direction. To calibrate the ACCEL TIME, turn the ACCEL TIME trim pot CW to increase the forward acceleration time and CCW to decrease the forward acceleration time.

**Deceleration (P6):** The DECEL TIME setting determines the time the motor takes to ramp to a lower speed when commanded by the potentiometer or analog signal, regardless of direction. To calibrate the DECEL TIME, turn the DECEL TIME trim pot CW to increase the deceleration time.

**Acceleration / Motoring Torque (P7):** The MOTOR CUR LIM setting determines the maximum torque (current) for accelerating and driving the motor in the forward or reverse directions. To calibrate the MOTOR CUR LIM:

1. With the power disconnected from the drive, connect a DC ammeter in series with the armature.
2. Set the MOTOR CUR LIM trim pot to minimum (full CCW).
3. Set the speed adjust potentiometer (full CW) or input voltage or current signal to maximum forward speed (full CW).
4. Carefully lock the motor armature. Be sure that the motor is firmly mounted.
5. Apply power source. The motor should be stopped.
6. Slowly adjust the MOTOR CUR LIM trim pot CW until the armature current is 150% of motor rated armature current.
7. Turn the speed adjust potentiometer to minimum speed (full CCW).
8. Remove power source.
9. Remove the stall from the motor.
10. Remove the ammeter in series with the motor armature if it is no longer needed.

**Deceleration / Regen Torque (P8):** The REGEN CUR LIM setting determines the maximum torque (current) for decelerating the motor and resisting an overhauling load in the forward and reverse directions. Turn the REGEN CUR LIM trim pot CW to increase the regen current limit and CCW to decrease the regen current limit.

**IR Compensation (P9):** The IR COMP setting determines the degree to which motor speed is held constant as the motor load changes. It is factory set for optimum motor regulation. To calibrate the IR COMP:

1. Set the IR COMP trim pot full CCW.
2. Increase the speed adjust potentiometer or input voltage or current signal until the motor runs at midspeed without load. A handheld tachometer may be used to measure motor speed.
3. Load the motor armature to its full load armature current rating. The motor should slow down.
4. While keeping the load on the motor, rotate the IR COMP trim pot until the motor runs at the speed measured in step 2. If the motor oscillates (overcompensation), the IR COMP trim pot may be set too high (CW). Turn the IR COMP trim pot CCW to stabilize the motor.
5. Unload the motor.